

IP54

Max.
1x15W3x2.5
mm²

230V

RoHS CE

**MALMBERGS**

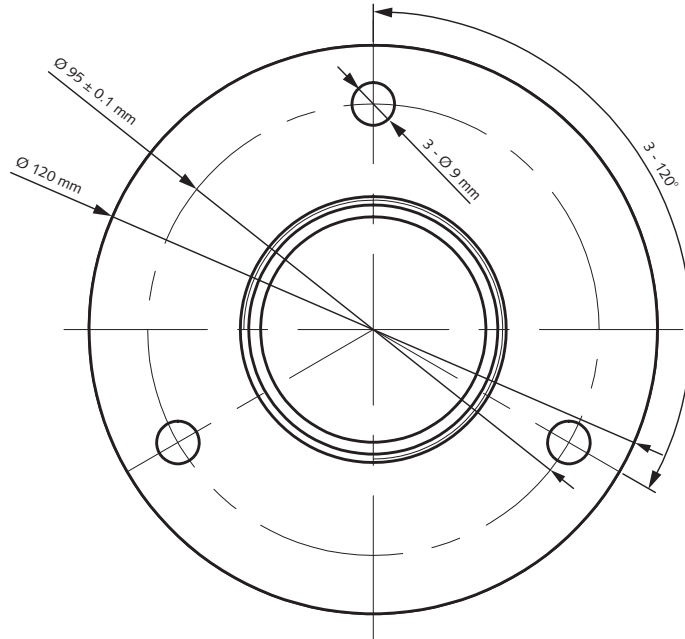
**EMC Standard (EMC)**

EN 55015:2013, EN 61547:2009, EN 61000-3-2:2014, EN 61000-3-3:2013

Safety Standard (LVD)

EN 60598-2-1:1989, EN 60598-1:2008+A11:2009, EN 62493:2010

RoHS Standard (RoHS)

IEC 62321:section 8/9/10, IEC 62321:section7, IEC 62321:Annex C, IEC 62321:Annex B, IEC 62321:Annex A

Declaration of Conformity

We hereby certify that the device satisfies the provisions for CE marking in accordance with the EU directives (LVD Directive 2006/95/EC, EMC Directive 2004/108/EC, RoHS Directive 2011/65/EU) as described in this manual.

For and on behalf of:

Malmbergs Elektriska AB, Sweden.
Mr. Anders Folke / Product Manager
Date: 24/11/2021