

•lykke•

ILMASTOINTILAITE

PORTABLE AC

PORTABEL AC

KLIMAANLAGE

PRO 3000

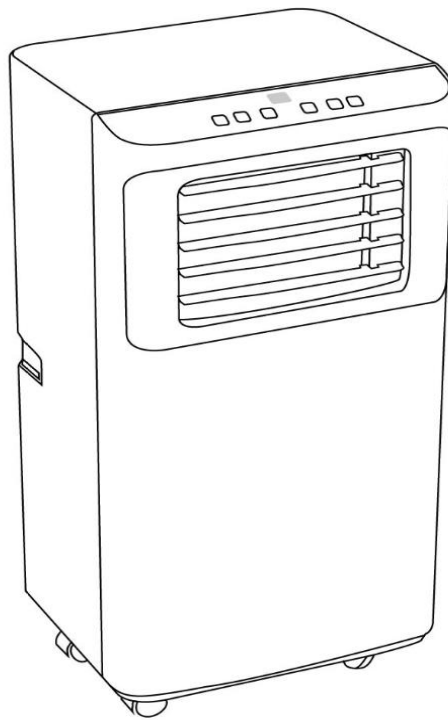

IP-Agency Finland Oy - All rights reserved. Product and instructions for use are subject to change. Technical information is subject to change without notice.

This version of the user manual has been translated from English. We reserve the right to make any translation errors. The translation is based on the official English version.

Importer:
IP-Agency Finland Oy
Honkanummentie 13, 01380 Vantaa
Finland

Please read this user's manual carefully to ensure proper use, maintenance and installation. Keep the manual for future reference, if you pass on the device, please give this manual with it.

IMPORTANT SAFETY INSTRUCTIONS

- The device is not intended for use by persons (including children) with reduced mobility, sensory or sensory, sensory or mental limitations, or who have no experience or knowledge of the use of the device, unless they are supervised or instructed by a person responsible for their safety on how to use the device. how to use the equipment safely.
- Children must be supervised so that they do not play with the device.
- EUROPEAN COUNTRIES ONLY: The device may be used by children and persons aged 8 years and over, who are physically, sensorially or mentally impaired or who do not have experience and knowledge of the use of the device, provided they are supervised or instructed in the safe use of the device and understand the risks involved.
- Children must not play with the device.
- Children must not carry out cleaning or maintenance operations without supervision.
- Keep the appliance and its power cord out of the reach of children under 8 years of age.
- Unplug the appliance for maintenance and replacement of parts.
- Warning: before handling connectors, all supply circuits must be disconnected.
- If the power cord is damaged, it should be replaced by the manufacturer, a service centre or by a qualified person in order to avoid any risk.
- Disconnect the plug from the socket before cleaning and maintenance.
- The appliance must not be installed in a laundry room.
- Do not use the appliance for any purpose other than that described in this manual.
- If the power cord becomes worn or damaged, only a qualified service technician should replace the cord using genuine spare parts.
- Make sure that the plug is firmly inserted in the socket. This can cause electric shock or risk of electric shock or fire.
- Do not share the socket with other appliances. This can create a risk of electric shock.
- Do not disassemble or modify the appliance or the power cord. Doing so may result in electric shock or fire hazard. All other servicing should be carried out by a professional installer.
- Do not place the power cord or appliance near heaters, radiators or other heat-generating devices. appliances that produce heat. Doing so may result in electric shock or fire hazard.
- This appliance is equipped with a cord having a grounding conductor connected to a grounding lug or a grounding strap. The plug must be connected to a properly installed and earthed grounded socket outlet. Under no circumstances cut or remove the grounding button or grounding strip from the plug.
- The appliance must be used or stored in such a way that it is protected from moisture, e.g. Unplug the appliance immediately if this is not the case.
- Always carry the appliance in an upright position and place it on a stable, level surface during use. If the appliance has been transported on its side, it should be allowed to settle and should not be connected to the current until 6 hours have elapsed.

Voltage: 220-240V/50HZ

Coolant: R290/145g(7000BTU) – R290/185g(9000BTU)

Cooling input power/current: 786W/3.42A(7000BTU) – 1008/4.38A(9000BTU)

Discharge side pressure: 2.6MPa(7000BTU) – 3.2MPa(9000BTU)

Suction side pressure sound: 1.0MPa(7000BTU) – 1.2MPa(9000BTU)

Noise level: 65dB

Energy class: A

Power consumption: 1,4kWh/60min

Extendable exhaust hose: 1,5m

Net/Gross weight: 18/20kgs

Contents

1. Safety Awareness	1
2. Name of Parts	12
3. Accessories	13
4. Appearance and Function of Control Panel	14
5. Appearance and Function of Remote Control	15
6. Operation Introduction	16
7. Installation Explanations	18
8. Maintenance Explanations	21
9. Troubleshooting.....	22

1. Safety Awareness

VERY IMPORTANT!

Please do not install or use your portable air conditioner before you have carefully read this manual. Please keep this instruction manual for an eventual product warranty and for future reference.

Warning

Do not use means to accelerate the defrosting process or to clean, other than those recommended by the manufacturer.

The appliance shall be stored in a room without continuously operating ignition sources (for example: open flames, an operating gas appliance or an operating electric heater.

Do not pierce or burn.

Be aware the refrigerants may not contain an odour.

Appliance shall be installed, operated and stored in a room with a floor area larger than X m².

MODEL	X (m ²)
5000Btu/h,7000Btu/h,8000Btu/h	4
9000Btu/h,10000Btu/h,10500Btu/h	12
12000Btu/h,14000,16000Btu/h,18000Btu/h	15

Specific information regarding appliances with R290 refrigerant gas.

Warning (for R290)

- Thoroughly read all of the warnings.
- When defrosting and cleaning the appliance , do not use any tools other than those recommended by the manufacturing company.
- The appliance must be placed in an area without any continuously sources of ignition (for example: open flames , gas or electrical appliances in operation).

- Do not puncture and do not burn.
- This appliance contains Y g (see rating label back of unit) of R290 refrigerant gas.
- R290 is a refrigerant gas that complies with the European directives on the environment. Do not puncture any part of the refrigerant circuit.
- If the appliance is installed, operated or stored in an unventilated area, the room must be designed to prevent to the accumulation of refrigerant leaks resulting in a risk of fire or explosion due to ignition of the refrigerant caused by electric heaters, stoves, or other sources of ignition.
- The appliance must be stored in such a way as to prevent mechanical failure.
- Individuals who operate or work on the refrigerant circuit must have the appropriate certification issued by an accredited organization that ensures competence in handling refrigerants according to a specific evaluation recognized by associations in the industry.
- Repairs must be performed based on the recommendation from the manufacturing company. Maintenance and repairs that require the assistance of other qualified personnel must be performed under the supervision of an individual specified in the use of flammable refrigerants.

General Safety Instruction

1. The appliance is for indoor use only.
2. Do not use the unit on a socket under repairs or not installed properly
3. Do not use the unit, follow these precautions:
 - A: Near to source of fire.
 - B: An area where oil is likely to splash.
 - C: An area exposed to direct sunlight.
 - D: An area where water is likely to splash.
 - E: Near a bath, a laundry, a shower or a swimming pool.
4. Never insert your fingers, rods into the air outlet. Take special care to warn children of these dangers.
5. Keep the unit upward while transport and storage, for the compressor locates properly.
6. Before cleaning the air-conditioner, always turn off or disconnect the power supply.
7. When moving the air-conditioner, always turn off and disconnect the power supply, and move it slowly.

8. To avoid the possibility of fire disaster, the air-conditioner shall not be covered.
9. All the air-conditioner sockets must comply with the local electric safety requirements. If necessary, please check it for the requirements.
10. Children should be supervised to ensure that they do not play with the appliance.
11. If the supply cord is damaged, it must be replaced by the manufacturer, its service agent or similarly qualified persons in order to avoid a hazard.
12. This appliance can be used by children aged from 8 years and above and persons with reduced physical, sensory or mental capabilities or lack of experience and knowledge if they have been given supervision or instruction concerning use of the appliance in a safe way and understand the hazards involved. Children shall not play with the appliance. Cleaning and user maintenance shall not be made by children without supervision.
13. The appliance shall be installed in accordance with national wiring regulations.
14. Details of type and rating of fuses: [T, 250V AC, 2A or higher](#).
15. Recycling



This marking indicates that this product should not be disposed with other household wastes throughout the EU. To prevent possible harm to the environment or human health from uncontrolled waste disposal, recycle it responsibly to promote the sustainable reuse of material resources. To return your used device, please use the return and collection systems or contact the retailer where the product was purchased. They can take this product for environmental safe recycling.

16. Contact authorized service technician for repair or maintenance of this unit.
17. Do not pull, deform or modify the power supply cord, or immerse it in water. Pulling or misuse of the power supply cord can result in damage to the unit and cause electrical shock.
18. Compliance with national gas regulations shall be observed.
19. Keep ventilation openings clear of obstruction.
20. Any person who is involved with working on or breaking into a refrigerant circuit should hold a current valid certificate from an industry-accredited assessment authority, which authorizes their

competence to handle refrigerants safely in accordance with an industry recognized assessment specification.

21. Servicing shall only be performed as recommended by the equipment manufacturer .

Maintenance and repair requiring the assistance of other skilled personnel shall be carried out under the supervision of the person competent in the use of flammable refrigerants.

22. Do not operate or stop the unit by inserting or pulling out Die power plug, it may cause electric shock or fire due to heat generation .

23. Unplug the unit if strange sounds, smell, or smoke comes from it.



Notes:

- If any parts damage, please contact the dealer or a designated repair shop;
- In case of any damage, please turn off the air switch, disconnect the power supply, and contact the dealer or a designated repair shop;
- In any case, the power cord shall be firmly grounded.
- To avoid the possibility of danger, if power cord is damaged, please turn off the air switch and disconnect the power supply. It must be replaced from the dealer or a designated repair shop.

INSTRUCTIONS FOR REPAIRING APPLIANCES CONTAINING R290

1 GENERAL INSTRUCTIONS

1.1 Checks to the area

Prior to beginning work on systems containing flammable refrigerants, safety checks are necessary to ensure that the risk of ignition is minimised. For repair to the refrigerating system, the following precautions shall be complied with prior to conducting work on the system.

1.2 Work procedure

Work shall be undertaken under a controlled procedure so as to minimise the risk of a flammable gas or vapour being present while the work is being performed.

1.3 General work area

All maintenance staff and others working in the local area shall be instructed on the nature of work being carried out. Work in confined spaces shall be avoided. The area around the workspace shall be sectioned off. Ensure that the conditions within the area have been made safe by control of flammable material.

1.4 Checking for presence of refrigerant

The area shall be checked with an appropriate refrigerant detector prior to and during work, to ensure the technician is aware of potentially flammable atmospheres. Ensure that the leak detection equipment being used is suitable for use with flammable refrigerants, i.e. nonsparking, adequately sealed or intrinsically safe.

1.5 Presence of fire extinguisher

If any hot work is to be conducted on the refrigeration equipment or any associated parts, appropriate fire extinguishing equipment shall be available to hand. Have a dry powder or CO₂ fire extinguisher adjacent to the charging area.

1.6 No ignition sources

No person carrying out work in relation to a refrigeration system which involves exposing any pipe work that contains or has contained flammable refrigerant shall use any sources of ignition in such a manner that it may lead to the risk of fire or explosion. All possible ignition sources, including cigarette smoking, should be kept sufficiently far away from the site of installation, repairing, removing and disposal, during which flammable refrigerant can possibly be released to the surrounding space. Prior to work taking place, the area around the equipment is to be surveyed to make sure that there are no flammable hazards or ignition risks. "No Smoking" signs shall be displayed.

1.7 Ventilated area

Ensure that the area is in the open or that it is adequately ventilated before breaking into the system or conducting any hot work. A degree of ventilation shall continue during the period that the work is carried out. The ventilation should safely disperse any released refrigerant and preferably expel it externally into the atmosphere.

1.8 Checks to the refrigeration equipment

Where electrical components are being changed, they shall be fit for the purpose and to the correct specification. At all times the manufacturer's maintenance and service guidelines shall be followed. If in doubt consult the manufacturer's technical department for assistance. The following checks shall be applied to installations using flammable refrigerants: the charge size is in accordance with

the room size within which the refrigerant containing parts are installed; the ventilation machinery and outlets are operating adequately and are not obstructed; if an indirect refrigerating circuit is being used, the secondary circuit shall be checked for the presence of refrigerant; marking to the equipment continues to be visible and legible. Markings and signs that are illegible shall be corrected; refrigeration pipe or components are installed in a position where they are unlikely to be exposed to any substance which may corrode refrigerant containing components, unless the components are constructed of materials which are inherently resistant to being corroded or are suitably protected against being so corroded.

1.9 Checks to electrical devices

Repair and maintenance to electrical components shall include initial safety checks and component inspection procedures. If a fault exists that could compromise safety, then no electrical supply shall be connected to the circuit until it is satisfactorily dealt with. If the fault cannot be corrected immediately but it is necessary to continue operation, an adequate temporary solution shall be used. This shall be reported to the owner of the equipment so all parties are advised.

Initial safety checks shall include: that capacitors are discharged: this shall be done in a safe manner to avoid possibility of sparking; that there no live electrical components and wiring are exposed while charging, recovering or purging the system; that there is continuity of earth bonding.

2 REPAIRS TO SEALED COMPONENTS

2.1 During repairs to sealed components, all electrical supplies shall be disconnected from the equipment being worked upon prior to any removal of sealed covers, etc. If it is absolutely necessary to have an electrical supply to equipment during servicing, then a permanently operating form of leak detection shall be located at the most critical point to warn of a potentially hazardous situation.

2.2 Particular attention shall be paid to the following to ensure that by working on electrical components, the casing is not altered in such a way that the level of protection is affected. This shall include damage to cables, excessive number of connections, terminals not made to original specification, damage to seals, incorrect fitting of glands, etc. Ensure that apparatus is mounted securely. Ensure that seals or sealing materials have not degraded such that they no longer serve the purpose of preventing the ingress of flammable atmospheres. Replacement parts shall be in accordance with the manufacturer's specifications.

NOTE The use of silicon sealant may inhibit the effectiveness of some types of leak detection equipment. Intrinsically safe components do not have to be isolated prior to working on them.

3 REPAIR TO INTRINSICALLY SAFE COMPONENTS

Do not apply any permanent inductive or capacitance loads to the circuit without ensuring that this will not exceed the permissible voltage and current permitted for the equipment in use.

Intrinsically safe components are the only types that can be worked on while live in the presence of a flammable atmosphere. The test apparatus shall be at the correct rating. Replace components only with parts specified by the manufacturer. Other parts may result in the ignition of refrigerant in the atmosphere from a leak.

4 CABLING

Check that cabling will not be subject to wear, corrosion, excessive pressure, vibration, sharp edges or any other adverse environmental effects. The check shall also take into account the effects of aging or continual vibration from sources such as compressors or fans.

5 DETECTION OF FLAMMABLE REFRIGERANTS

Under no circumstances shall potential sources of ignition be used in the searching for or detection of refrigerant leaks. A halide torch (or any other detector using a naked flame) shall not be used.

6 LEAK DETECTION METHODS

The following leak detection methods are deemed acceptable for systems containing flammable refrigerants. Electronic leak detectors shall be used to detect flammable refrigerants, but the sensitivity may not be adequate, or may need recalibration. (Detection equipment shall be calibrated in a refrigerant-free area.) Ensure that the detector is not a potential source of ignition and is suitable for the refrigerant used. Leak detection equipment shall be set at a percentage of the LFL of the refrigerant and shall be calibrated to the refrigerant employed and the appropriate percentage of gas (25 % maximum) is confirmed. Leak detection fluids are suitable for use with most refrigerants but the use of detergents containing chlorine shall be avoided as the chlorine may react with the refrigerant and corrode the copper pipe-work. If a leak is suspected, all naked flames shall be removed/extinguished. If a leakage of refrigerant is found which requires brazing, all of the refrigerant shall be recovered from the system, or isolated (by means of shut off valves) in a part of the system remote from the leak. Oxygen free nitrogen (OFN) shall then be purged through the system both before and during the brazing process.

7 REMOVAL AND EVACUATION

When breaking into the refrigerant circuit to make repairs – or for any other purpose – conventional procedures shall be used. However, it is important that best practice is followed since flammability is a consideration. The following procedure shall be adhered to: remove refrigerant; purge the circuit with inert gas; evacuate; purge again with inert gas; open the circuit by cutting or brazing. The refrigerant charge shall be recovered into the correct recovery cylinders. The system shall be “flushed” with OFN to render the unit safe. This process may need to be repeated several times. Compressed air or oxygen shall not be used for this task. Flushing shall be achieved by breaking the vacuum in the system with OFN and continuing to fill until the working pressure is achieved, then venting to atmosphere, and finally pulling down to a vacuum. This process shall be repeated until no refrigerant is within the system. When the final OFN charge is used, the system shall be vented down to atmospheric pressure to enable work to take place. This operation is absolutely vital if brazing operations on the pipework are to take place.

Ensure that the outlet for the vacuum pump is not close to any ignition sources and there is ventilation available.

8 CHARGING PROCEDURES

In addition to conventional charging procedures, the following requirements shall be followed.

- Ensure that contamination of different refrigerants does not occur when using charging equipment. Hoses or lines shall be as short as possible to minimise the amount of refrigerant contained in them.
- Cylinders shall be kept upright.
- Ensure that the refrigeration system is earthed prior to charging the system with refrigerant.
- Label the system when charging is complete (if not already).
- Extreme care shall be taken not to overfill the refrigeration system.

Prior to recharging the system it shall be pressure tested with OFN. The system shall be leak tested on completion of charging but prior to commissioning. A follow up leak test shall be carried out prior to leaving the site.

9 DECOMMISSIONING

Before carrying out this procedure, it is essential that the technician is completely familiar with the equipment and all its detail. It is recommended good practice that all refrigerants are recovered safely. Prior to the task being carried out, an oil and refrigerant sample shall be taken in case analysis is required prior to re-use of reclaimed refrigerant. It is essential that electrical power is available before the task is commenced.

- a) Become familiar with the equipment and its operation.
- b) Isolate system electrically.
- c) Before attempting the procedure ensure that :mechanical handling equipment is available, if required, for handling refrigerant cylinders; all personal protective equipment is available and being used correctly; the recovery process is supervised at all times by a competent person; recovery equipment and cylinders conform to the appropriate standards.
- d) Pump down refrigerant system,if possible.
- e) If a vacuum is not possible, make a manifold so that refrigerant can be removed from various parts of the system.
- f) Make sure that cylinder is situated on the scales before recovery takes place.
- g) Start the recovery machine and operate in accordance with manufacturer's instructions.
- h) Do not overfill cylinders. (No more than 80 % volume liquid charge).
- i) Do not exceed the maximum working pressure of the cylinder,even temporarily.
- j) When the cylinders have been filled correctly and the process completed, make sure that the cylinders and the equipment are removed from site promptly and all isolation valves on the equipment are closed off.
- k) Recovered refrigerant shall not be charged into another refrigeration system unless it has been cleaned and checked.

10 LABELLING

Equipment shall be labelled stating that it has been de-commissioned and emptied of refrigerant. The label shall be dated and signed.

Ensure that there are labels on the equipment stating the equipment contains flammable refrigerant.

11 RECOVERY

When removing refrigerant from a system, either for servicing or decommissioning, it is recommended good practice that all refrigerants are removed safely. When transferring refrigerant into cylinders, ensure that only appropriate refrigerant recovery cylinders are employed. Ensure that the correct number of cylinders for holding the total system charge are available. All cylinders to be used are designated for the recovered refrigerant and labelled for that refrigerant (i.e. special cylinders for the recovery of refrigerant). Cylinders shall be complete with pressure relief valve and associated shut-off valves in good working order. Empty recovery cylinders are evacuated and, if possible, cooled before recovery occurs.

The recovery equipment shall be in good working order with a set of instructions concerning the equipment that is at hand and shall be suitable for the recovery of flammable refrigerants. In

addition, a set of calibrated weighing scales shall be available and in good working order. Hoses shall be complete with leak-free disconnect couplings and in good condition. Before using the recovery machine, check that it is in satisfactory working order, has been properly maintained and that any associated electrical components are sealed to prevent ignition in the event of a refrigerant release. Consult manufacturer if in doubt.

The recovered refrigerant shall be returned to the refrigerant supplier in the correct recovery cylinder, and the relevant Waste Transfer Note arranged. Do not mix refrigerants in recovery units and especially not in cylinders.

If compressors or compressor oils are to be removed, ensure that they have been evacuated to an acceptable level to make certain that flammable refrigerant does not remain within the lubricant. The evacuation process shall be carried out prior to returning the compressor to the suppliers. Only electric heating to the compressor body shall be employed to accelerate this process. When oil is drained from a system, it shall be carried out safely.

Competence of service personnel

General

Special training additional to usual refrigerating equipment repair procedures is required when equipment with flammable refrigerants is affected.

In many countries, this training is carried out by national training organisations that are accredited to teach the relevant national competency standards that may be set in legislation.

The achieved competence should be documented by a certificate.

Training

The training should include the substance of the following:

Information about the explosion potential of flammable refrigerants to show that flammables may be dangerous when handled without care.

Information about potential ignition sources, especially those that are not obvious, such as lighters, light switches, vacuum cleaners, electric heaters.

Information about the different safety concepts:

Unventilated – (see Clause GG.2) Safety of the appliance does not depend on ventilation of the housing. Switching off the appliance or opening of the housing has no significant effect on the safety. Nevertheless, it is possible that leaking refrigerant may accumulate inside the enclosure and flammable atmosphere will be released when the enclosure is opened.

Ventilated enclosure – (see Clause GG.4) Safety of the appliance depends on ventilation of the housing. Switching off the appliance or opening of the enclosure has a significant effect on the safety. Care should be taken to ensure a sufficient ventilation before.

Ventilated room – (see Clause GG.5) Safety of the appliance depends on the ventilation of the room. Switching off the appliance or opening of the housing has no significant effect on the safety. The ventilation of the room shall not be switched off during repair procedures.

Information about the concept of sealed components and sealed enclosures according to IEC 60079-15:2010.

Information about the correct working procedures:

a) Commissioning

- Ensure that the floor area is sufficient for the refrigerant charge or that the ventilation duct is assembled in a correct manner.
- Connect the pipes and carry out a leak test before charging with refrigerant.
- Check safety equipment before putting into service.

b) Maintenance

- Portable equipment shall be repaired outside or in a workshop specially equipped for servicing units with flammable refrigerants.
- Ensure sufficient ventilation at the repair place.
- Be aware that malfunction of the equipment may be caused by refrigerant loss and a refrigerant leak is possible.
- Discharge capacitors in a way that won't cause any spark. The standard procedure to short circuit the capacitor terminals usually creates sparks.
- Reassemble sealed enclosures accurately. If seals are worn, replace them.
- Check safety equipment before putting into service.

c) Repair

- Portable equipment shall be repaired outside or in a workshop specially equipped for servicing units with flammable refrigerants.
- Ensure sufficient ventilation at the repair place.
- Be aware that malfunction of the equipment may be caused by refrigerant loss and a refrigerant leak is possible.
- Discharge capacitors in a way that won't cause any spark.
- When brazing is required, the following procedures shall be carried out in the right order:
 - Remove the refrigerant. If the recovery is not required by national regulations, drain the refrigerant to the outside. Take care that the drained refrigerant will not cause any danger. In doubt, one person should guard the outlet. Take special care that drained refrigerant will not float back into the building.
 - Evacuate the refrigerant circuit.
 - Purge the refrigerant circuit with nitrogen for 5 min.
 - Evacuate again.
 - Remove parts to be replaced by cutting, not by flame.
 - Purge the braze point with nitrogen during the brazing procedure.
 - Carry out a leak test before charging with refrigerant.
- Reassemble sealed enclosures accurately. If seals are worn, replace them.
- Check safety equipment before putting into service.

d) Decommissioning

- If the safety is affected when the equipment is putted out of service, the refrigerant charge shall be removed before decommissioning.
- Ensure sufficient ventilation at the equipment location.
- Be aware that malfunction of the equipment may be caused by refrigerant loss and a refrigerant leak is possible.
- Discharge capacitors in a way that won't cause any spark.
- Remove the refrigerant. If the recovery is not required by national regulations, drain the refrigerant to the outside. Take care that the drained refrigerant will not cause any danger. In doubt, one person should guard the outlet. Take special care that drained refrigerant will not float back into the building.
- Evacuate the refrigerant circuit.
- Purge the refrigerant circuit with nitrogen for 5 min.
- Evacuate again.
- Fill with nitrogen up to atmospheric pressure.

- Put a label on the equipment that the refrigerant is removed.

e) Disposal

- Ensure sufficient ventilation at the working place.
- Remove the refrigerant. If the recovery is not required by national regulations, drain the refrigerant to the outside. Take care that the drained refrigerant will not cause any danger. In doubt, one person should guard the outlet. Take special care that drained refrigerant will not float back into the building.
- Evacuate the refrigerant circuit.
- Purge the refrigerant circuit with nitrogen for 5 min.
- Evacuate again.
- Cut out the compressor and drain the oil.

Transportation, marking and storage for units that employ flammable refrigerants

Transport of equipment containing flammable refrigerants

Attention is drawn to the fact that additional transportation regulations may exist with respect to equipment containing flammable gas. The maximum number of pieces of equipment or the configuration of the equipment, permitted to be transported together will be determined by the applicable transport regulations.

Marking of equipment using signs

Signs for similar appliances used in a work area generally are addressed by local regulations and give the minimum requirements for the provision of safety and/or health signs for a work location.

All required signs are to be maintained and employers should ensure that employees receive suitable and sufficient instruction and training on the meaning of appropriate safety signs and the actions that need to be taken in connection with these signs.

The effectiveness of signs should not be diminished by too many signs being placed together. Any pictograms used should be as simple as possible and contain only essential details.

Disposal of equipment using flammable refrigerants

See national regulations.

Storage of equipment/appliances

The storage of equipment should be in accordance with the manufacturer's instructions.

Storage of packed (unsold) equipment

Storage package protection should be constructed such that mechanical damage to the equipment inside the package will not cause a leak of the refrigerant charge.

The maximum number of pieces of equipment permitted to be stored together will be determined by local regulations.

2. Name of Parts

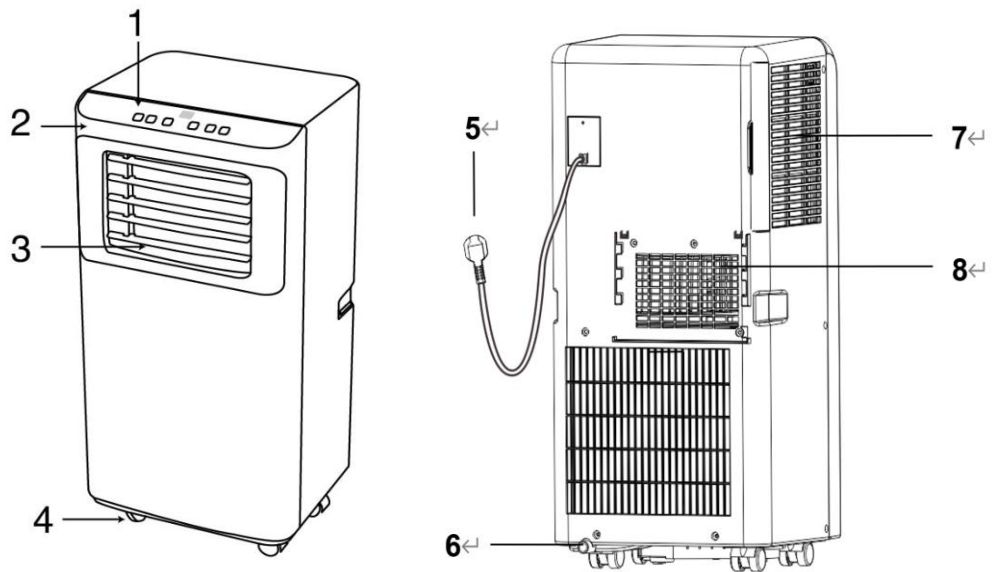



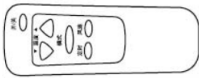





Fig.1

1	Control panel	5	Power cord
2	Front panel	6	Drainage outlet
3	Louver	7	Air inlet
4	Castor	8	Air outlet

3. Accessories

Part	Description	Quantity
	Exhaust hose	1
	Window Connector	1
	Housing adaptor	1
	Remote Controller	1
	Window Kit	1 (optional)
	T slot screw translation	3 (optional)
	Water pipe	1 (optional)
	Batteries	2 (optional)

After unpacking, please check whether the above-mentioned accessories are included, and check their purposes in the installation introduction in this manual.

4. Appearance and Function of Control Panel

Cooling only model

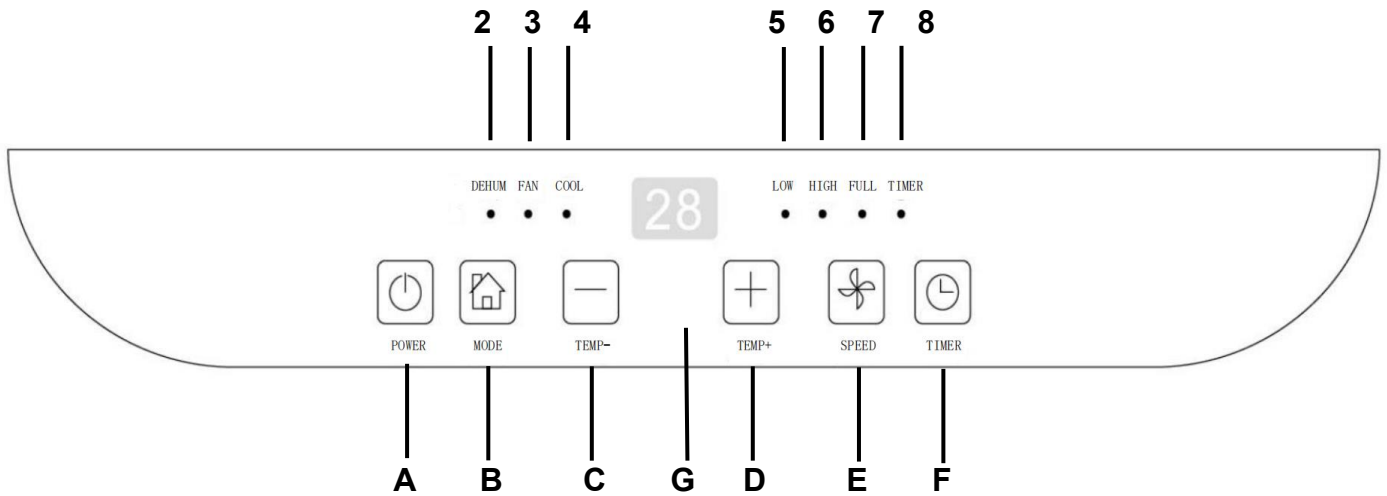

A	Power on/off		
B	Operation MODE	2	Dehumidifying
C	Temperature down	3	Fan
D	Temperature up	4	Cooling
E	Fan speed	5	Low fan speed
F	Timer on/off	6	High fan speed
G	Signal receiver	7	Water full
		8	Timer on/off

Cooling & Heating model

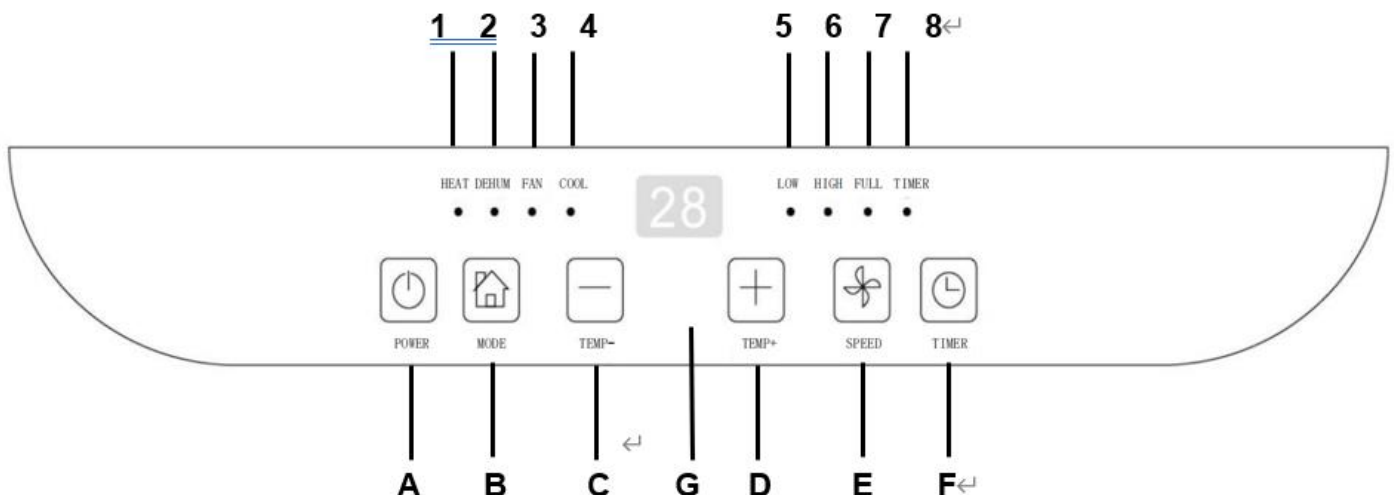

A	Power on/off	1	Heating
B	Operation MODE	2	Dehumidifying
C	Temperature down	3	Fan
D	Temperature up	4	Cooling

E	Fan speed	5	Low fan speed
F	Timer on/off	6	High fan speed
G	Signal receiver	7	Water full
		8	Timer on/off

5. Appearance and Function of Remote Control

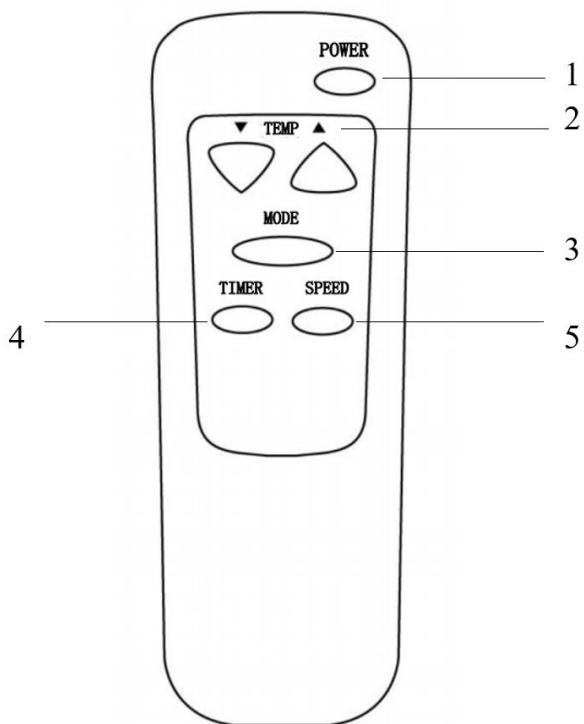

1	Power on/off
2	Temperature up/down
3	Operation MODE
4	Timer on/off
5	Fan speed

Notes:

- Do not drop the remote control.
- Do not place the remote control in a location exposed to direct sunlight.

6. Operation Introduction

Before starting operations in this section:

- 1) Find a place where there is power supply nearby.
- 2) As shown in Fig.2 and Fig.2a, install the exhaust hose, and adjust the window position well.

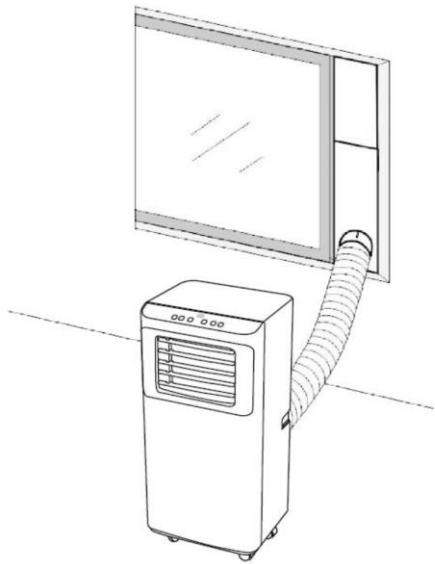

Fig.2

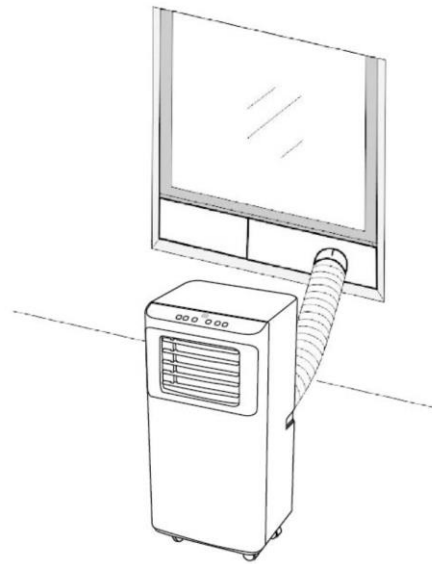

Fig.2a

- 3) As shown in Fig. 6, connect drain hose well (only for using heating model);
- 4) Insert the power cord into an grounded **AC220~240V/50Hz** socket;
- 5) Press the POWER button to turn on the air-conditioner.

1.Before using

Notice:

- Operation temperature range:

	Maximum cooling	Minimum cooling
DB/WB(°C)	35/24	18/12

	Maximum heating	Minimum heating
DB/WB(°C)	27/---	7/---

Check up whether the exhaust hose has been mounted properly.

Cautions for cooling and dehumidifying operations:

- When using functions on cooling and dehumidifying, keep an interval of at least 3 minutes between each POWER.
- Power supply meets the requirements.
- The socket is for AC use.
- Do not share one socket with other appliances.
- Power supply is **AC220-240V, 50Hz**

2. Cooling operation

- Press the “Mode” button till the “Cool” icon appears.
- Press the “▲” or “▼” button to select a desired room temperature. (16°C-31°C)
- Press the “Fan Speed” button to select wind speed.

3. Dehumidifying operation

Press the “Mode” button till the “Dehumidify” icon appears .

- Automatically set the selected temperature to current room temperature minus 2°C.
- Automatically set the fan motor to LOW wind speed.

4. Fan operation

- Press the “Mode” button till the “Fan” icon appears.
- Press the “Fan Speed” button to select wind speed.

5. Heating operation (this function is not available for a cold-single unit)

- Press the “Mode” button till the “Heat” icon appears.
- Press the “▲” or “▼” button to select a desired room temperature. (16°C-31°C)
- Press the “Fan Speed” button to select wind speed.

6. Timer operation

Timer ON setting:

- When the air-conditioner is OFF, press the “Timer” button and select a desired ON time through the temperature and time setting buttons.
- “Preset ON Time” is displayed on the operation panel.
- ON time can be regulated at any time in 0-24 hours.

Timer OFF setting

- When the air-conditioner ON, press “Timer” button and select a desired OFF time through the temperature and time setting buttons.
- “Preset OFF Time” is displayed on the operation panel.
- OFF time can be regulated at any time in 0-24 hours.

7. Water Drainage

Water Full Alarm Function

The inner water tray in the air-conditioner has one water level safety switches, it controls the water level. When water level reaches an anticipated height, the water full indicator lights up. When the water is full, please remove the rubber blockage from the drainage hole at the bottom of unit, and drain all water outside.

Continuous Drainage

- When you plan to leave this unit unused for a long time, please remove the rubber blockage from the drainage hole at the bottom of unit, and drain all water outside.
- You can use the continuous drainage with a drainage hose connected to the bottom drain hole, when the unit working at the HEAT mode.
- The continuous drainage is not need to be applied when the unit working at the COOL or DEHUMIDIFY mode. The unit can evaporate the condensate water automatically by the splash

motor. Make sure the drainage holes are stemmed well.

- If water splash motor is damaged, continuous drainage can be used. To connect the drain hose to the bottom drain hole (Fig.6), the unit can also work well.
- If splash motor is damaged, intermittent drainage can also be used. Under this condition, when the water full indicator lights up, please connect a drain hose to the bottom drainage hole, then all the water in the water tank will be drained outside. The unit can also work well.

7. Installation Explanations

1. Installation Explanations:

- A removal air-conditioner shall be installed in the flat and empty place all around. Don't block the air outlet, and the required distance around should be at least 30cm. (See Fig.3)
- Should not be installed in wet location, such as the laundry room.
- Socket wiring should be in accordance with the local electric safety requirements.

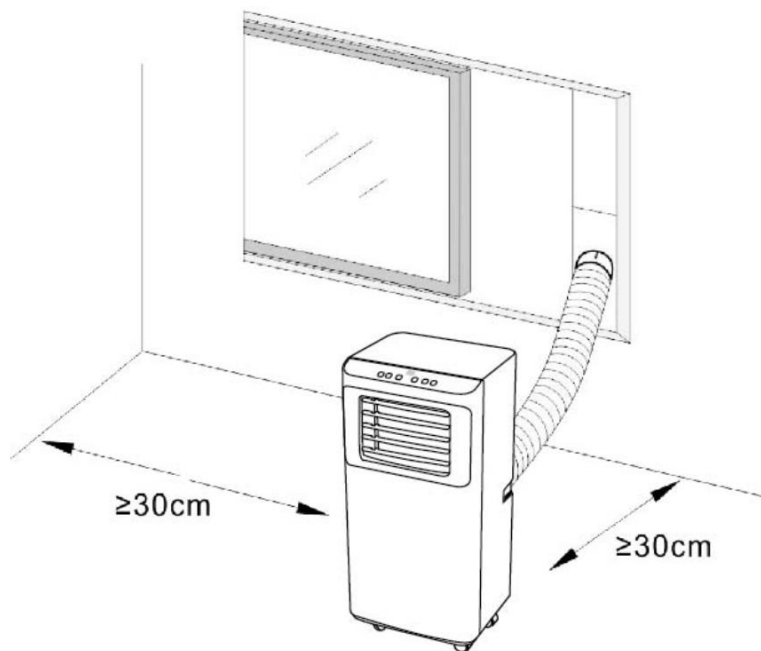

Fig.3

2. Introduction to Exhaust Hose Installation

A) Temporary installation

1. Twist the housing adaptor and the window Connector to the ends of the exhaust hose.
2. Insert the fixing clip of the housing adaptor into the openings at back of the air conditioner.
3. Put the other end of the exhaust hose to the near windowsill (see Fig.4).

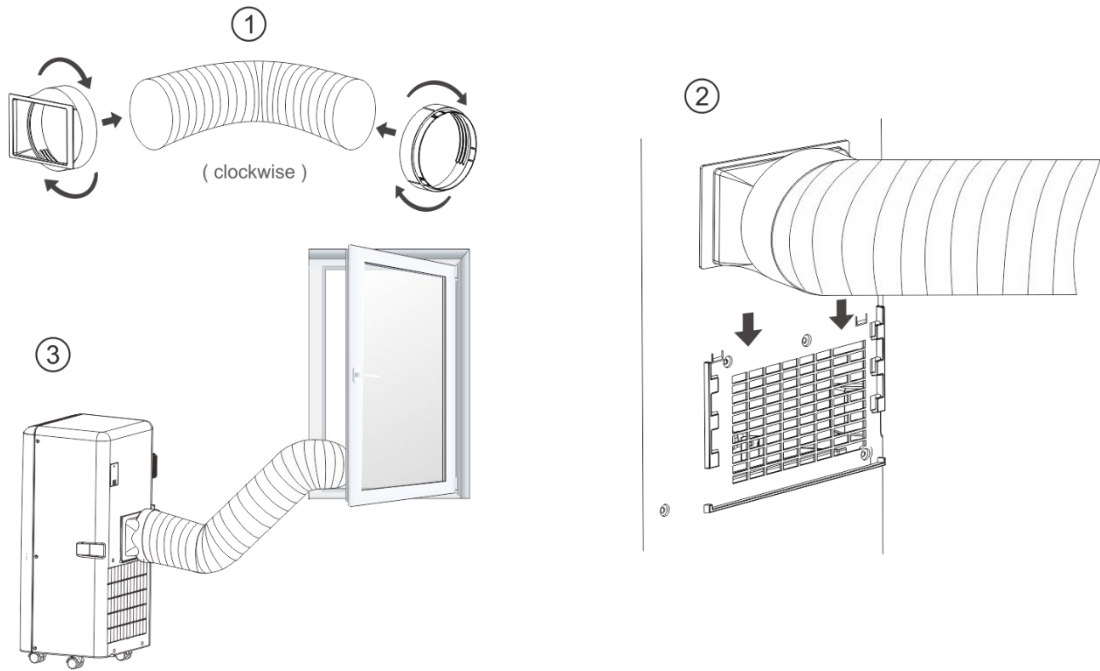
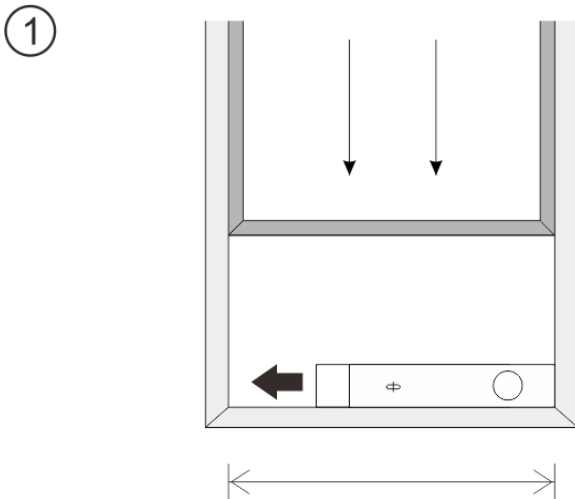

Fig.4

B) Window Kit Installation

The installation manner of window slider kit is mostly in “horizontal” or “vertical”. As shown Fig.5 and Fig.5a, check the min. and max. size of the window before the installation.

1. Install the window kit on the window (Fig.5, Fig.5a);
2. Adjust the length of the window slider kit according to the window width or height, and fix it with the dowel;
3. Insert the window connector of the hose to the hole of the window kit(Fig.5b)



Window width
min:67.5cm
max:123cm

Fig.5

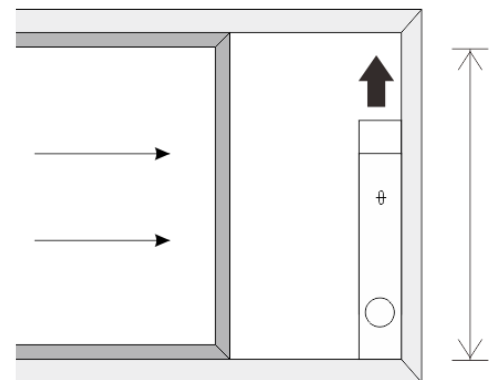

Window height
min:67.5cm
max:123cm

Fig.5a

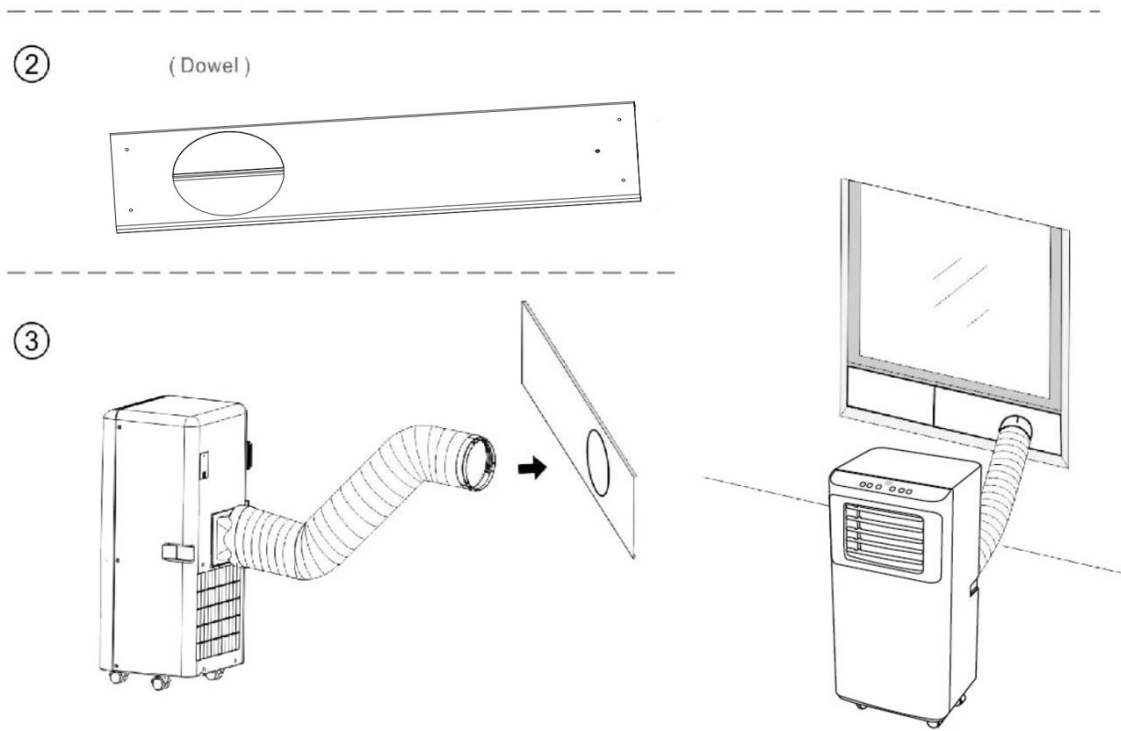

Water Full Alarm Function

The inner water tray in the air-conditioner has one water level safety switches, it controls water level. When water level reaches an anticipated height, the water full indicator lamp lights up. (If water splash motor is damaged, when the water is full, please remove the rubber blockage at the bottom of unit, and all water will drain outside.)

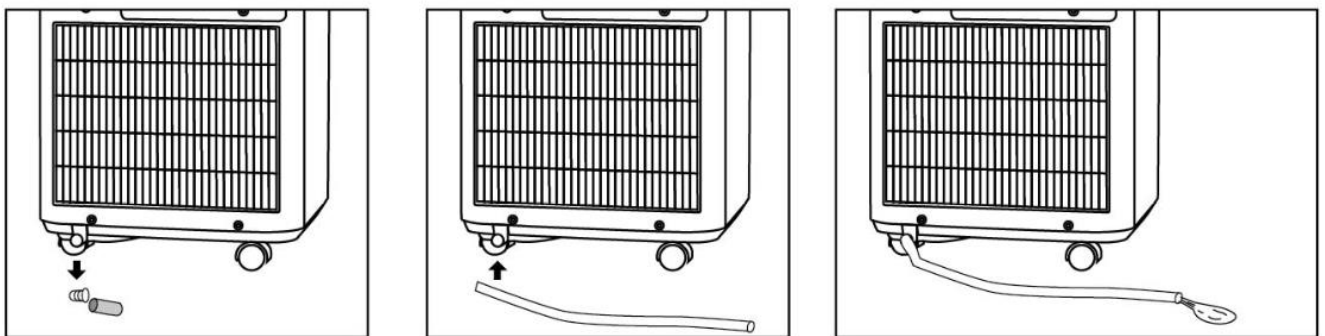
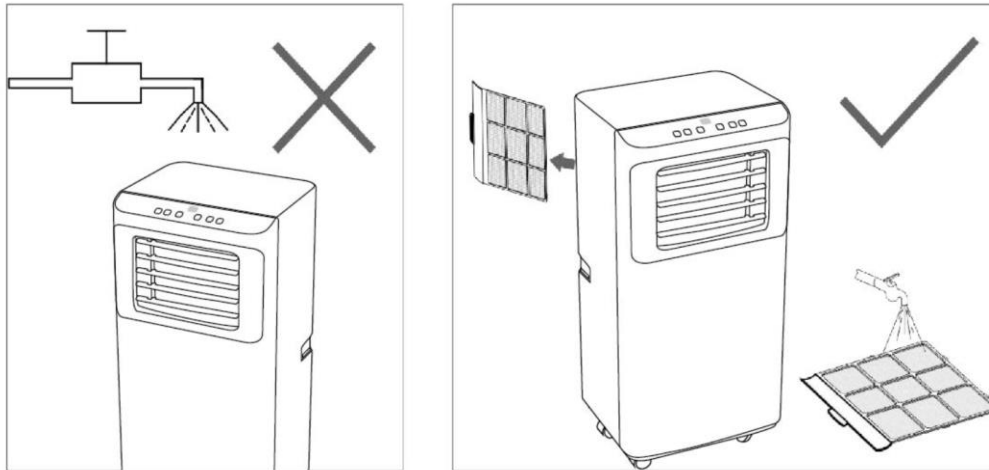

Fig.6

8. Maintenance Explanations

Declaration:

- 1) Before cleaning, be sure to disconnect the unit from any electric supply outlet;
- 2) Do not use gasoline or other chemicals to clean the unit;
- 3) Do not wash the unit directly;
- 4) If the conditioner is damaged, please contact the dealer or repair shop.



1. Air Filter

- If the air filter becomes clogged with dust/dirt, the air filter should be cleaned once every two weeks.
- Dismounting
Open the air inlet grille and take off air filter.
- Cleaning
Clean the air filter with neutral detergent in lukewarm (40°C) and dry it up in the shade.
- Mounting
Putting the air filter into the inlet grille, replace the components as they were.

2. Clean the Air-conditioner Surface

First clean the surface with a neutral detergent and wet cloth, and then wipe it with a dry cloth.

9. Troubleshooting

Troubles	Possible Causes	Suggested Remedies
1. Unit does not start when pressing on/off button	- Water full indicator lamp blinks, and water tray is full.	Dump the water out of the water tray.
	- Room temperature is higher than the setting temperature. (Electric heating mode)	Reset the temperature
	- Room temperature is lower than the setting temperature. (Cooling mode)	Reset the temperature
2. Not cool enough	- The doors or windows are not closed.	Make sure all the windows and doors are closed.
	- There are heat sources inside the room.	Remove the heat sources if possible
	- Exhaust air hose is not connected or blocked.	Connect or clean the exhaust air hose.
	- Temperature setting is too high.	Reset the temperature
	- Air inlet is blocked.	Clean the air inlet.
3. Noisy	- The ground is not level or not flat enough	Place the unit on a flat, level ground if possible
	- The sound comes from the flowing of the refrigerant inside the air conditioner	It is normal.
4. E0 Code	Room temperature sensor failed	Replace room temperature sensor (the unit can also work without replacement.)
5. E1 Code	Condenser temperature sensor failed	Replace condenser temperature sensor
6. E2 Code	Water tray full when cooling	Take off rubber stopper and empty the water.
7. E3 Code	Evaporator temperature sensor failed	Replace evaporator temperature sensor
8. E4 Code	Water tray full when heating	Please empty the water tray.

Note: The real products may look different.

Correct Disposal of this product	
	This marking indicates that this product should not be disposed with other household wastes throughout the EU. To prevent possible harm to the environment or human health from uncontrolled waste disposal, recycle it responsibly to promote the sustainable reuse of material resources.



EU Declaration of Conformity

*EU-vaatimusten mukaisuusvakuutus – EU-försäkran om
överensstämmelse - EU-Konformitätserklärung*

Manufacturer	IP-Agency Finland Oy
Address	Honkanummentie 13, 01380 Vantaa, Finland.
Website	www.ip-agency.fi

DECLARES THAT DESIGN AND MANUFACTURING OF THE FOLLOWING PRODUCT COMPLIES WITH THE FOLLOWING DIRECTIVES AND STANDARDS AND IS IDENTICAL TO THE PRODUCT.

VAKUUTTA, ETTÄ SEURAAVAN TUOTTEEN RAKENNE JA VALMISTUS OVAT SEURAAVIEN DIREKTIIVIEN JA STANDARDIEN MUKAISIA JA YHDENMUKAINEN TUOTTEEN KANSSA.

INTYGAR ATT KONSTRUKTION OCH TILLVERKNING AV FÖLJANDE PRODUKT ÖVERENSSTÄMMER MED FÖLJANDE DIREKTIV OCH STANDARDER OCH ÄR IDENTISK MED DEN PRODUKT.

ERKLÄRT, DASS DESIGN UND HERSTELLUNG DES FOLGENDEN PRODUKTS DEN FOLGENDEN RICHTLINIEN UND NORMEN ENTSPRECHEN UND MIT DEM PRODUKT IDENTISCH SIND.

Brand	Lykke
Product	Portable air conditioner
Model number(s)	WAP1-07C, WAP1-09C

Directives - Direktiivit – Direktiv – Richtlinie:

Rohs: 180213312a 001
Erp: CN21HYXQ 001 and CN21VDKV 001
EMC: CN21BMJ3 001

Standards - Standardit – Standarder – Normen:

IEC 62321-3-1:2013
EN IEC 55014-1:2021
EN IEC 55014-2:2021
EN 61000-3-3:2013+A1
EN IEC 61000-3-2:2019+A1
EN 14511-2:2018
EN14511-3:2018
EN 50564:2011
EN 12102-1:2017.



Jouki Puurtinen, CEO
