

CS-EB3 (3MP)













Smart Home Battery Camera

Introduction

EZVIZ products have been designed for your entertainment, communication and security. EB3 is a 2K wire-free security camera with a long-lasting 5200mAh rechargeable battery and 100% wire-free design.



Main Features

- | | | | | | |
|---|---------------------------|---|---|---|-----------------------------|
|  | 2K Resolution |  | Up to 120 Days Battery Life (5200mAh) |  | Active Defense |
|  | Support Micro SD Card |  | Color Night Vision |  | Works with Google Assistant |
|  | Two-Way Talk |  | Smart Human Motion Detection |  | Works with Amazon Alexa |
|  | Customizable Voice Alerts |  | Works with EZVIZ Solar Panel for battery charging | | |
| H.265 | H.265 Video Compression |  | Wi-Fi 2.4GHz | | |

Dimension

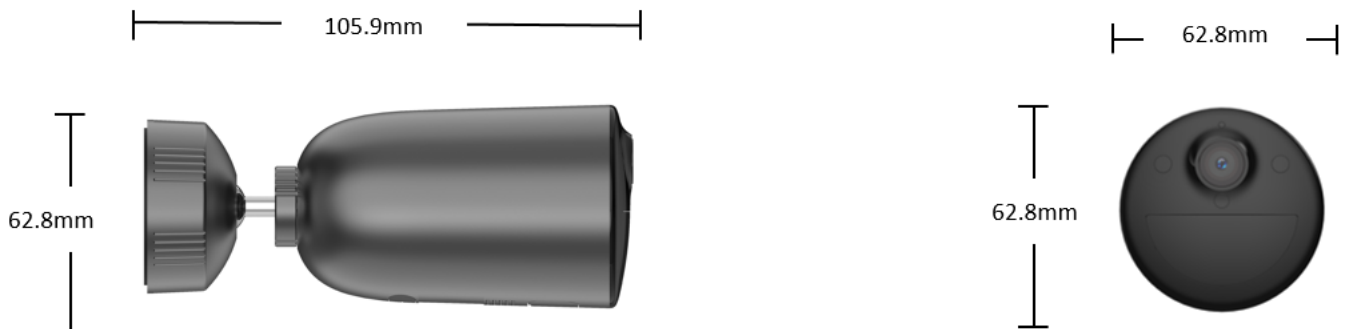

Specifications

Model	CS-EB3 (3MP)
Version	R100-2C3WFL
Camera	
Image sensor	1/2.8" 3-Megapixel Progressive Scan SMOS Sensor
Minimum Illumination	0.01 Lux @(F2.0, AGC ON), 0 Lux with IR
Shutter Speed	Self-adaptive shutter
Lens	2.8mm@ F2.0 Diagonal angle: 131° Horizontal angle: 110° Vertical angle: 58°
Day & Night	IR-cut filter with auto switch
DNR	3D DNR
Night Vision	IR Distance:15m, Color Night Vision Distance:15m
Video & Audio	
Max Resolution	2304 x 1296
Frame Rate	15fps. Self-Adaptive during network transmission
Video Compression	H.265/H.264
Video Bit Rate	Ultra-HD; Full HD; Hi-Def Adaptive bit rate.
Audio Bit Rate	Self-Adaptive
Max. Bitrate	1.5 Mbps
Network	
Wi-Fi Standard	IEEE802.11b, 802.11g, 802.11n
Frequency Range	2.4 GHz ~ 2.4835 GHz
Channel Bandwidth	Support 20MHz
Security	64/128-bit WEP, WPA/WPA2, WPA-PSK/WPA2-PSK
Transmission Rate	11b: 11Mbps,11g :54Mbps,11n :72Mbps
Wi-Fi Pairing	AP pairing
Protocol	EZVIZ cloud proprietary protocol
Interface Protocol	EZVIZ cloud proprietary protocol
Minimum Network Requirement	4Mbps
Function	
Smart Alarm	AI Human Detection
Two-way Talk	Supports
General Function	Anti-Flicker, Heart Beat, Password Protection, Watermark
Storage	
Local Storage	Support Micro SD slot for local storage (Up to 256G)
Cloud Storage	EZVIZ cloud storage
General	
Operating Conditions	-20°C to 50°C (-4°F to 122 °F), Humidity 95% or less (non-condensing)
IP Grade	IP65
Power Supply	DC 5V/2A (Compatible power adapter needs to be purchased separately)
Battery Capacity	5200 mAh
Power Consumption	Max.10W
Product Dimensions	105.9mm x 62.8mm x 62. 8mm
Packaging Dimensions	103*103*186mm
Weight	522g (with package)